

# POHLAD ZHORA M 1:50

TOP ELEVATION  
OBERANSICHT

REZ 2 - 2  
SECTION  
SCHNITT

VERZIA S ROLETOU  
ROLLER VERSION

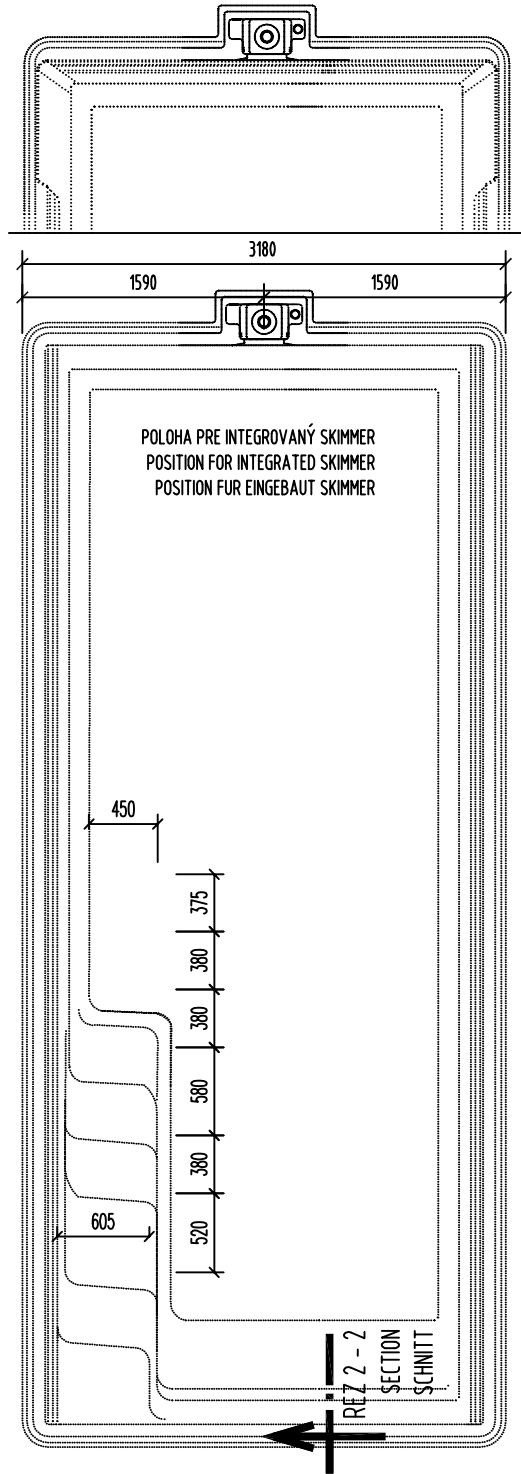

REZ 1 - 1  
SECTION  
SCHNITT

7400

REZ 1 - 1  
SECTION  
SCHNITT

REZ 2 - 2 M 1:50  
LONGITUDINAL SECTION  
QUERSCHNITT

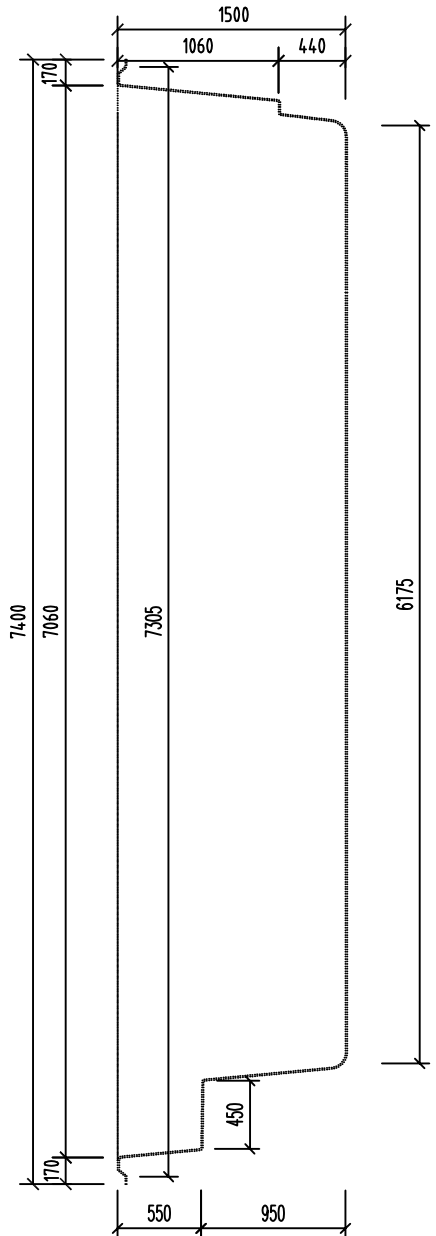

## REZ 1 - 1 M 1:50

CROSS SECTION  
QUERSCHNITT

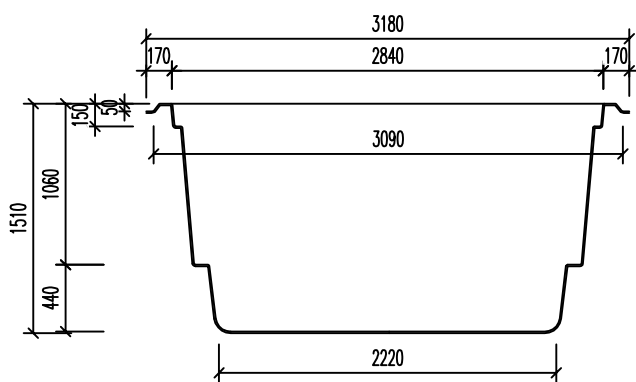

POZNÁMKA / NOTE / ANMERKUNG :

HRÚBKA STENY BAZÉNA JE CCA. 10 MM  
TOLERANCIA PRESNOSTI 7 - 10 MM

THICKNESS OF THE SIDEWALL OF SWIMMING POOL IS APPROX. 10 MM.  
MEASURED WITH TOLERANCE RATE 7 - 10 MM

DIE SCHWIMMBADWAND DÜCKE IS CA. 10 MM.  
DUCKENTOLERANZ IST 7 - 10 MM.

POOL HIGH FOR CONTAINER FOR SEA TRANSPORT IS 3080MM.

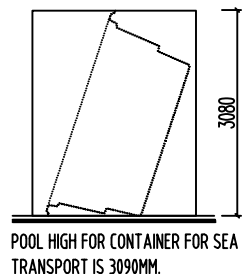

POOL HIGH FOR CONTAINER FOR SEA TRANSPORT IS 3090MM.

## DETAIL ÚPRAVY INTEGROVANÝ SKIMMER M 1:25

DETAIL FOR INTEGRATED SKIMMER  
DETAIL FÜR EINGEBAUT SKIMMER

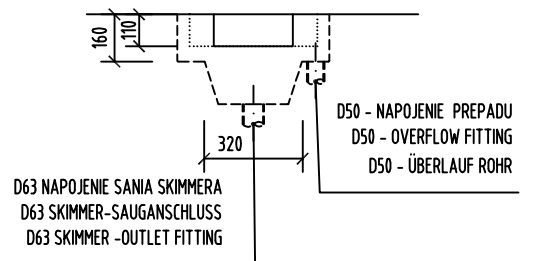

FIXÁCIA PLAVÁKU HLADINY  
FIXATION FOR WATER LEVEL FLOAT  
ELEMENT FIXIERUNG FÜR WASSERHOHE

D63 NAPOJENIE SANIA SKIMMERA  
D63 SKIMMER-SAUGANSCHLUSS  
D63 SKIMMER -OUTLET FITTING

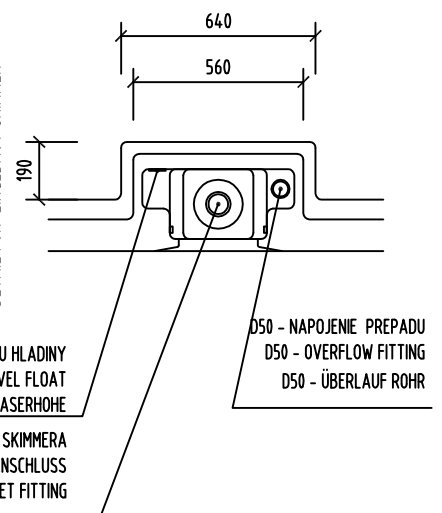

NÁZOV VÝKRESU:  
DRAWING NAME:  
ZEICHNUNG NAME:

**CLASSIC 73**  
**GEOMETRIA BAZÉNA**  
GEOMETRY OF SWIMMING POOL  
**SCHWIMMBAD GEOMETRIE**

**COMPASS**  
*enjoy the moment*

[www.compasspools.eu](http://www.compasspools.eu)

KRESLIL: DRAWN BY / ZEICHNER:	ING. PETER KALETA	DÁTUM: DATUM / DATUM:	12/2022
MIERKA: SCALE/MASSTABE:	1:50	FORMÁT DRAWING FORMAT / ZEICHNUNG FORMAT:	A3
VERZIA: VERSION: VERSION:	1	ČÍSLO DRAWING NUMBER: ZEICHNUNG NUMBER:	1