

BORDER DETAIL
 BORD DETAIL
 DETAIL LEMU
SCALE 1:10
 MASSTABBE
 MIERKA

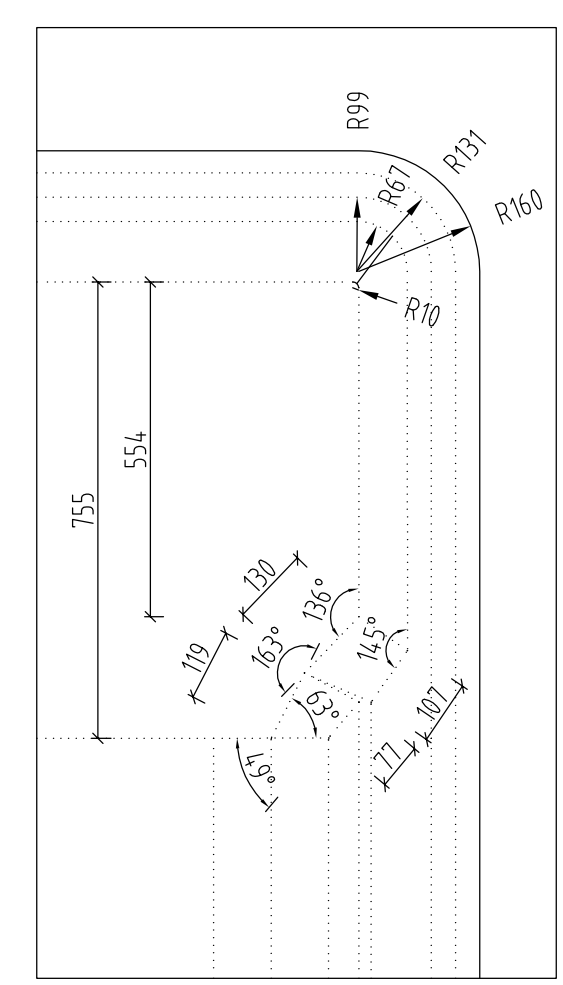

ROLLER NICHE DETAIL
 ROLLADEN NISCHE DETAIL
 DETAIL NIKY PRE ROLETU
SCALE 1:10
 MASSTABBE
 MIERKA

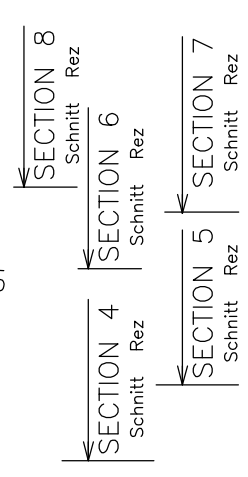

WALL DETAIL IN SECTION 3-3
 WAND DETAIL FÜR QUERSCHNITT 3-3
 DETAIL STENY PRE REZ 3-3
SCALE 1:10
 MASSTABBE
 MIERKA

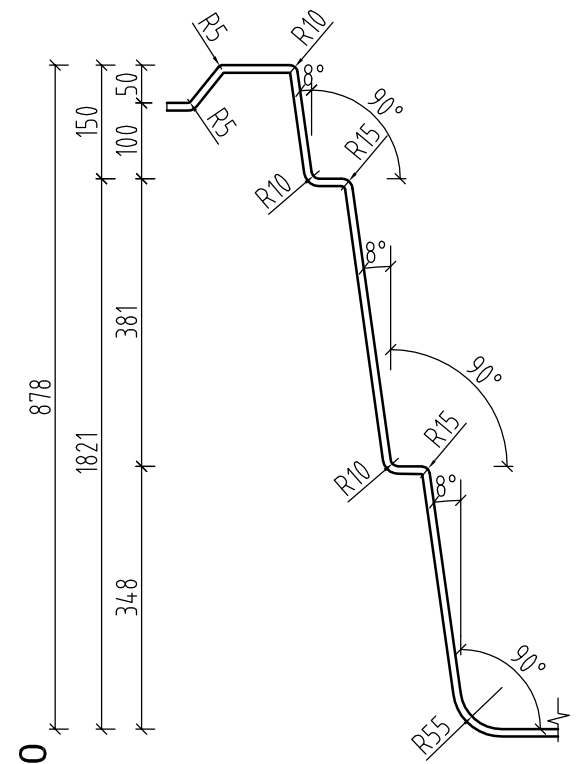

WALL DETAIL IN SECTION 3-3
 WAND DETAIL FÜR QUERSCHNITT 3-3
 DETAIL STENY PRE REZ 3-3
SCALE 1:10
 MASSTABBE
 MIERKA

NOTE/AMERKUNG/POZNÁMKA :
 THICKNESS OF THE SIDEWALL OF SWIMMING POOL IS
 APX. 10 MM
 MESURED WITH TOLERANCE RATE 7- 10 MM
 DIE SCHWIMMBADWAND DÜCKE IS CA. 10 MM.
 DÜCKENTOLERANZ IST 7 - 10 MM.
 HRÚBKÁ STENY BAZÉNA JE CCA. 10 MM
 TOLERANCIA PRESNOSTI 7 - 10 MM

GEOMETRY OF SWIMMING POOL
 SCHWIMMBAD GEOMETRIE
 GEOMETRIA BAZÉNA

XL TRAINER 62.25
(2012)

No: **01**
 FORMAT: **A3**
 SCALE: **M1:25**

CROSS SECTION 9-9

QUERSCHNITT
REZ

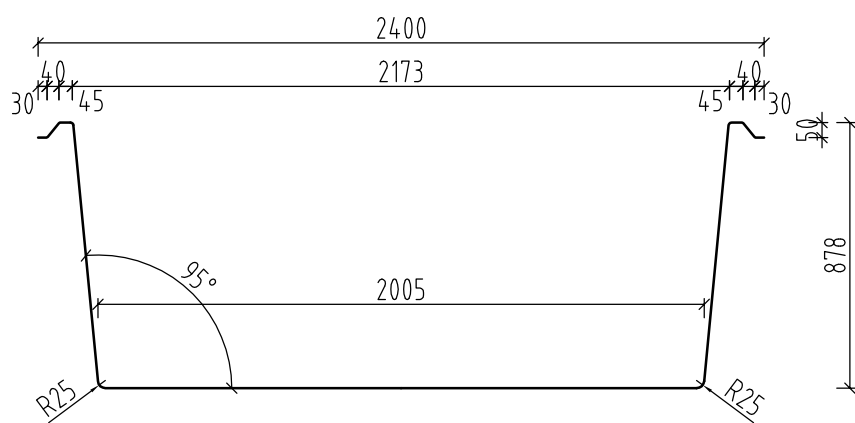

LONGITUDINAL SECTION 2-2

LANGLICHSCHNITT
REZ

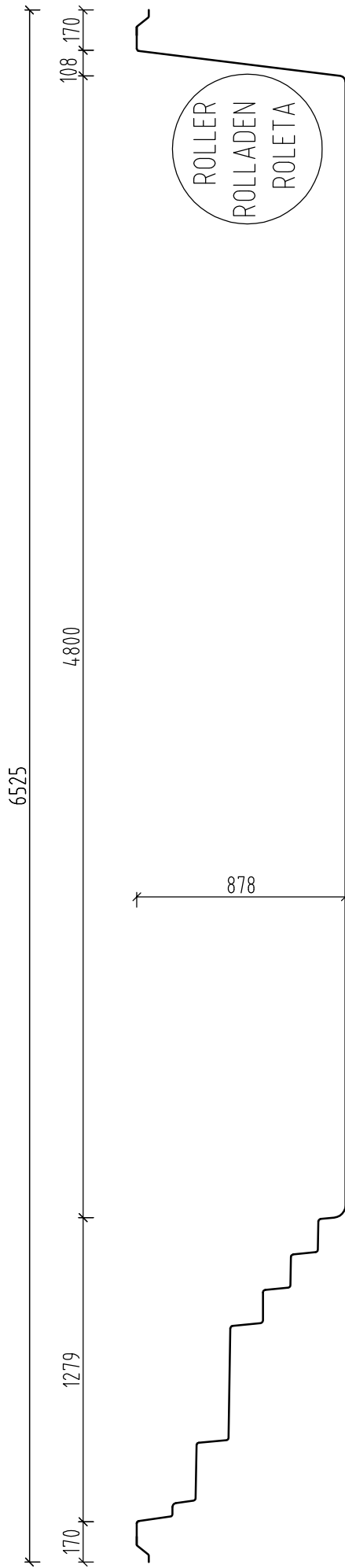

LONGITUDINAL SECTION 1-1

LANGLICHSCHNITT
REZ

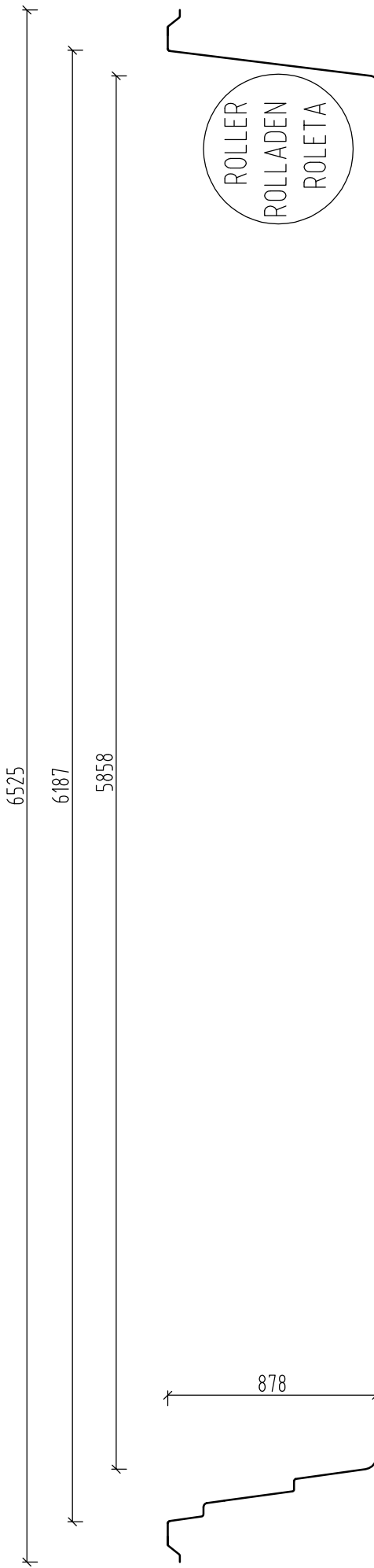

WALL DETAIL IN SECTION 9-9

WAND DETAIL FÜR QUERSCHNITT9-9
DETAIL STENY PRE REZ 9-9

SCALE 1:10

MASSTABBE
MIERKA

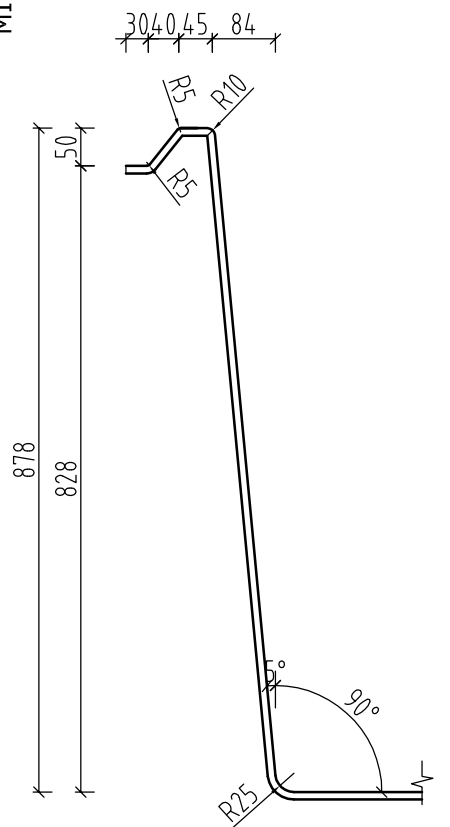

WALL DETAIL IN SECTION 1-1

WAND DETAIL FÜR QUERSCHNITT1-1
DETAIL STENY PRE REZ 1-1

SCALE 1:10

MASSTABBE
MIERKA

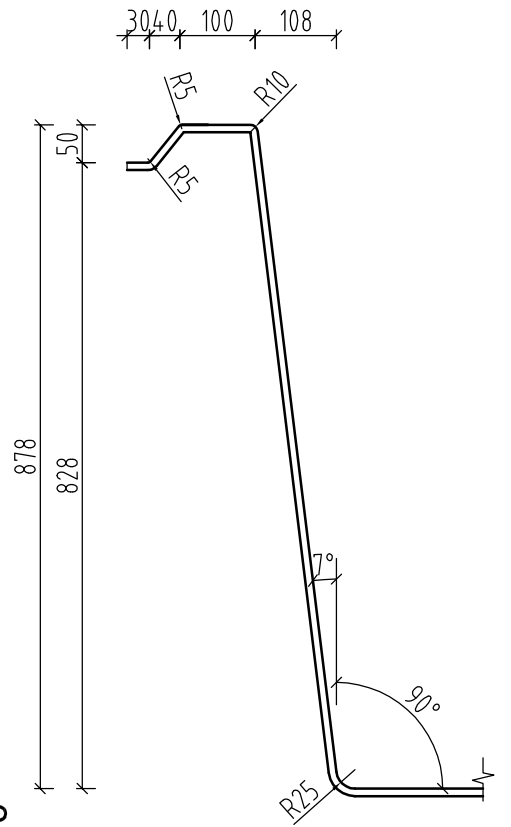

NOTE/AMERKUNG/POZNÁMKA :

TIKNESS OF THE SIDEWALL OF SWIMIG POOL IS
APX. 10 MM

MESURED WITH TOLERANCE RATE 7- 10 MM

DIE SCHWIMMBADWAND DUCKE IS CA. 10 MM.

DUCKENTOLERANZ IST 7 - 10 MM.

HRÚBKA STENY BAZÉNA JE CCA. 10 MM

TOLERANCIA PRESNOSTI 7 - 10 MM

GEOMETRY OF SWIMMING POOL

SCHWIMMBAD GEOMETRIE

GEOMETRIA BAZÉNA

XL TRAINER 62.25
(2012)

No: 02

FORMAT: A3

SCALE: M1:25

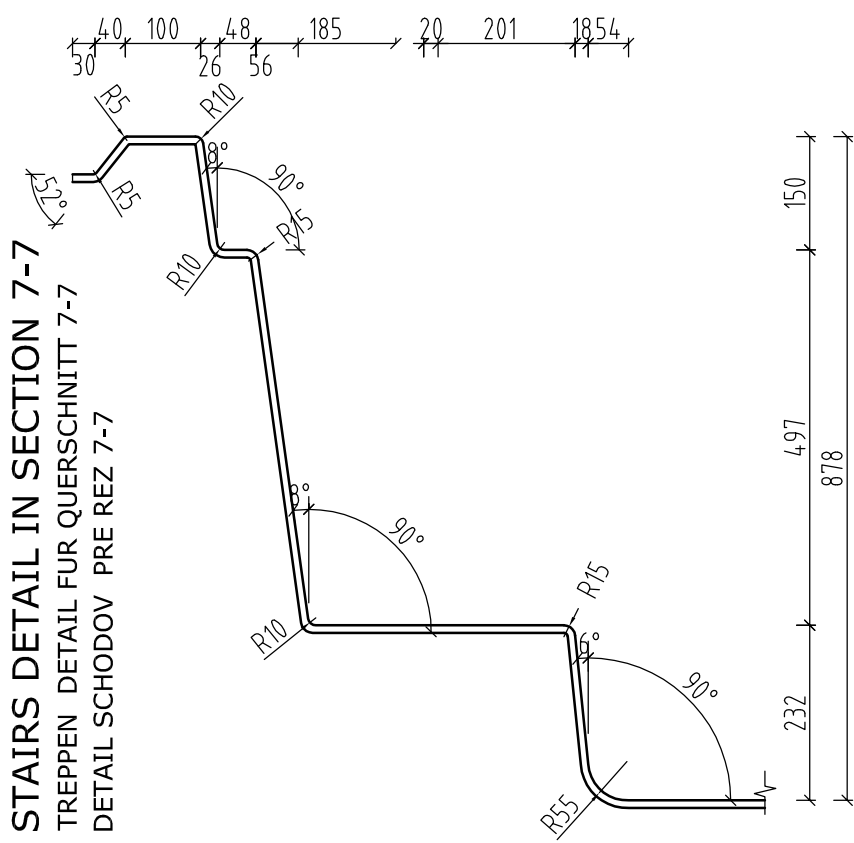
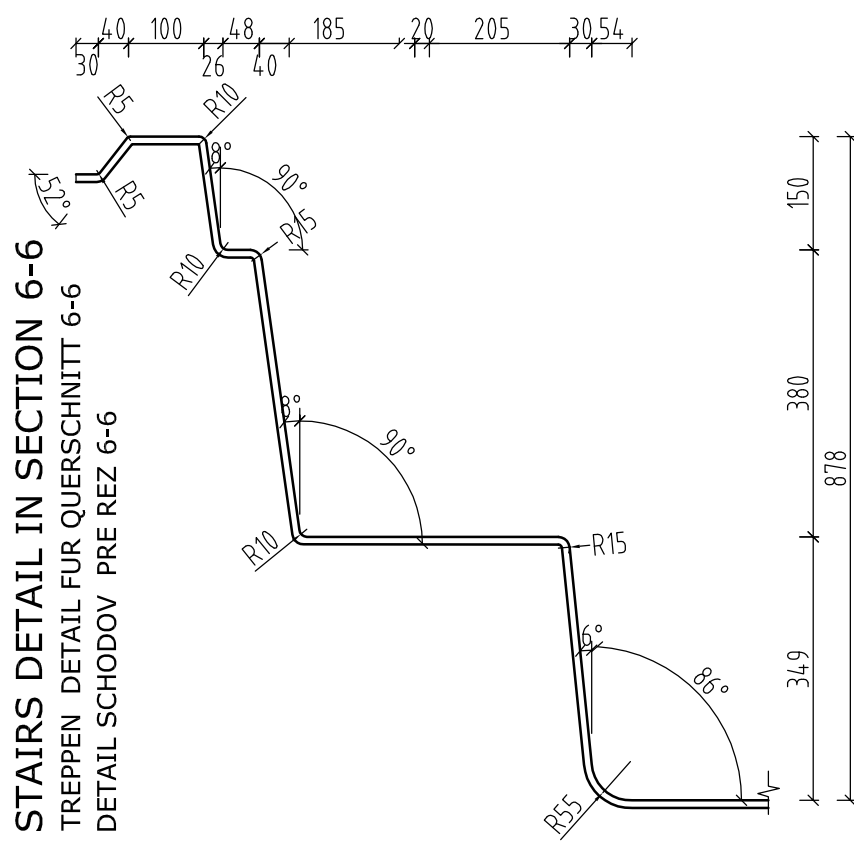
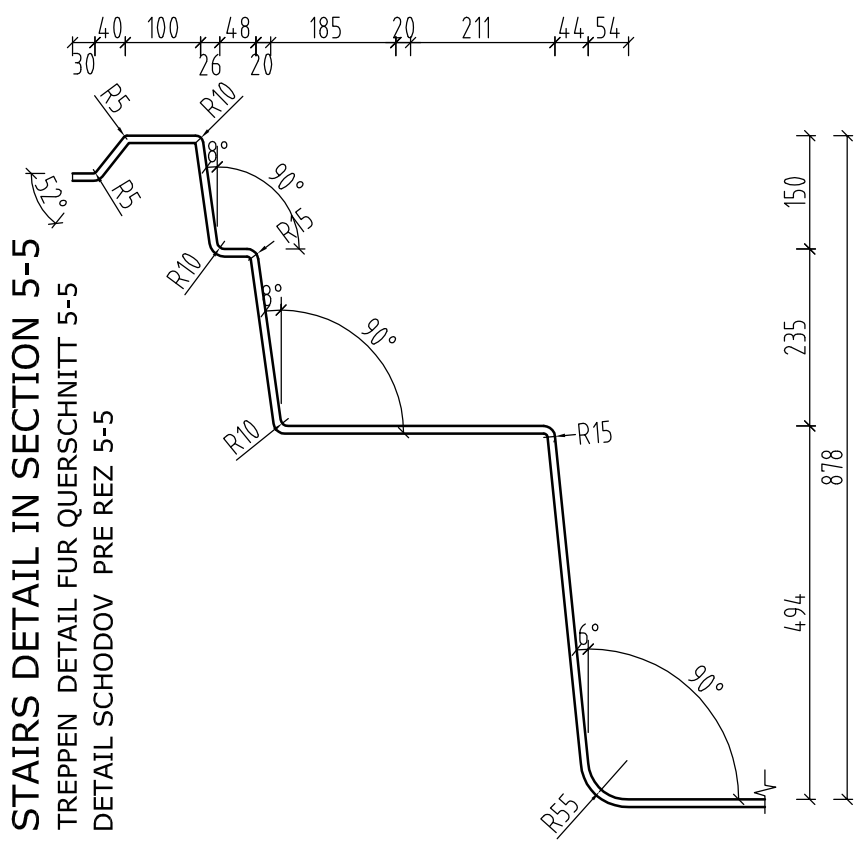
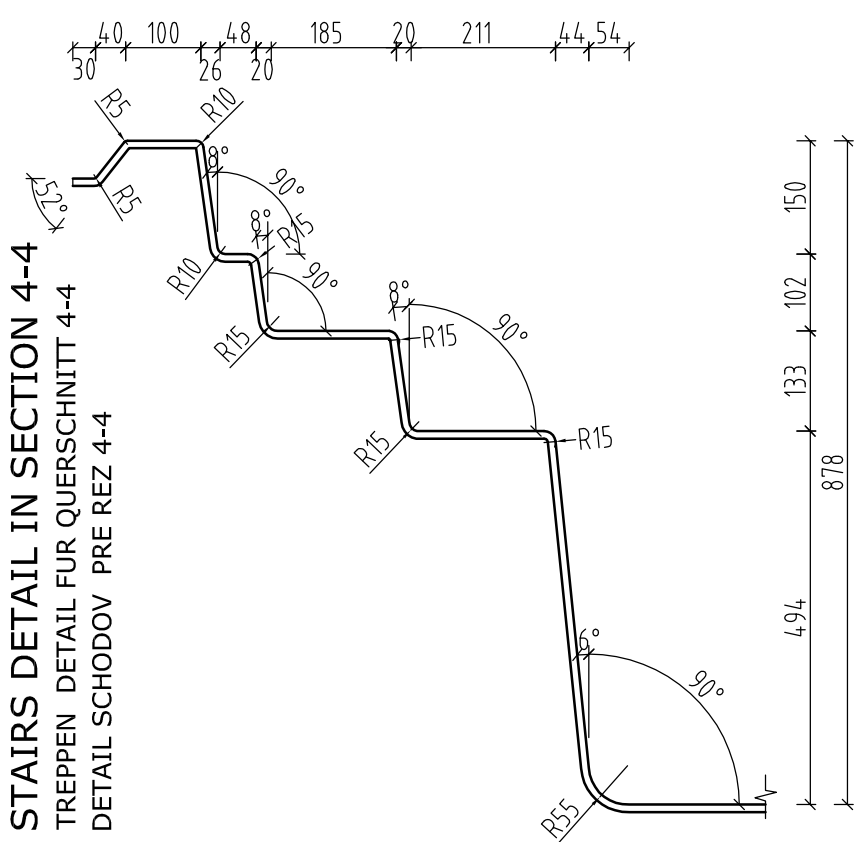
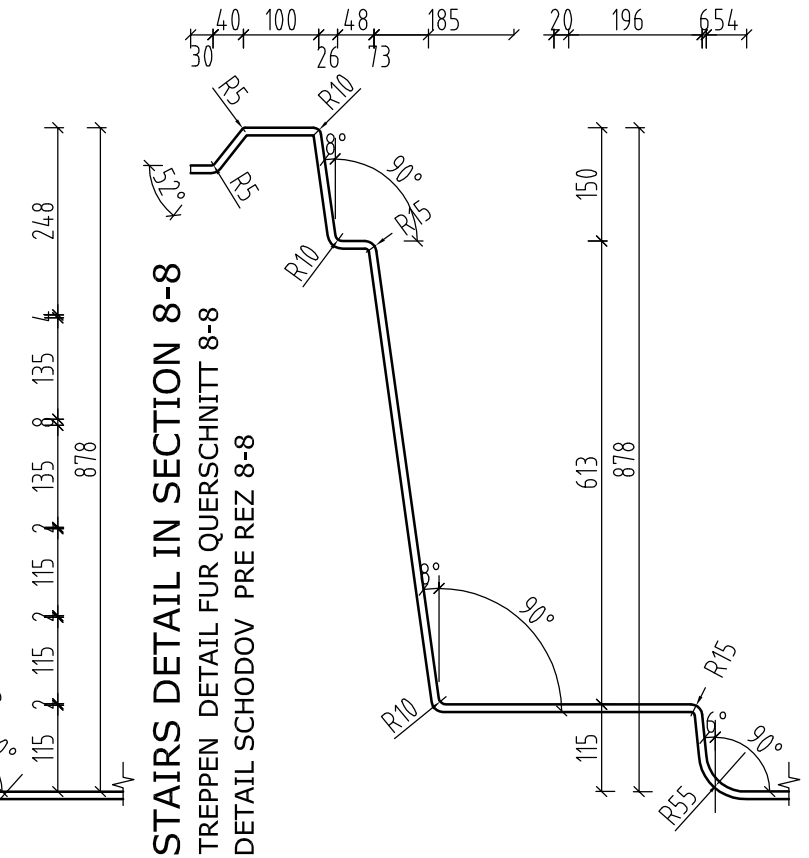
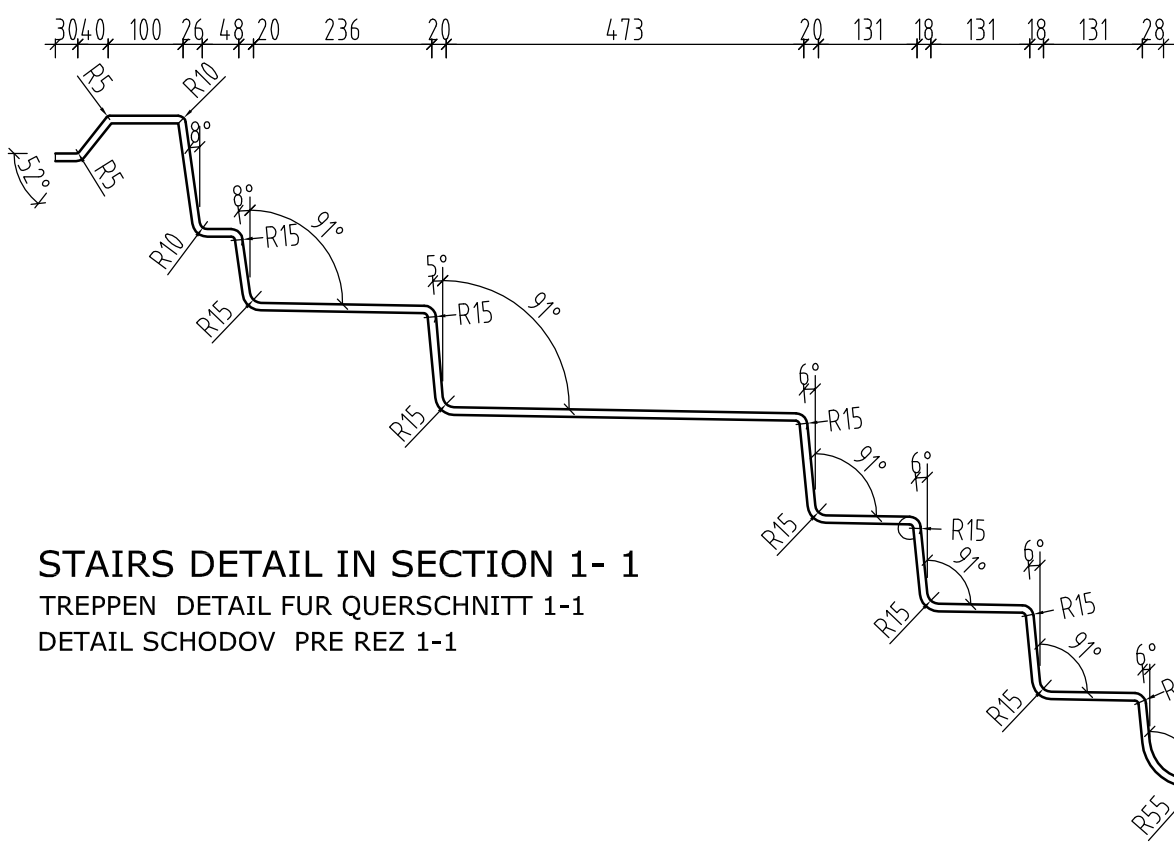

NOTE/AMERKUNG/POZNÁMKA :

TICKNESS OF THE SIDEWALL OF SWIMIG POOL IS
 APX. 10 MM
 MESURED WITH TOLERANCE RATE 7- 10 MM
 DIE SCHWIMMBADWAND DUCKE IS CA. 10 MM.
 DUCKENTOLERANZ IST 7 - 10 MM.
 HRÚBKA STENY BAZÉNA JE CCA. 10 MM
 TOLERANCIA PRESNOSTI 7 - 10 MM

GEOMETRY OF SWIMMING POOL
 SCHWIMMBAD GEOMETRIE
 GEOMETRIA BAZÉNA

XL TRAINER 62.25
 (2012)

No: 03
 FORMAT: A3
 SCALE: M1:10