

# POHLAD ZHORA M 1:50

TOP ELEVATION  
OBERANSICHT

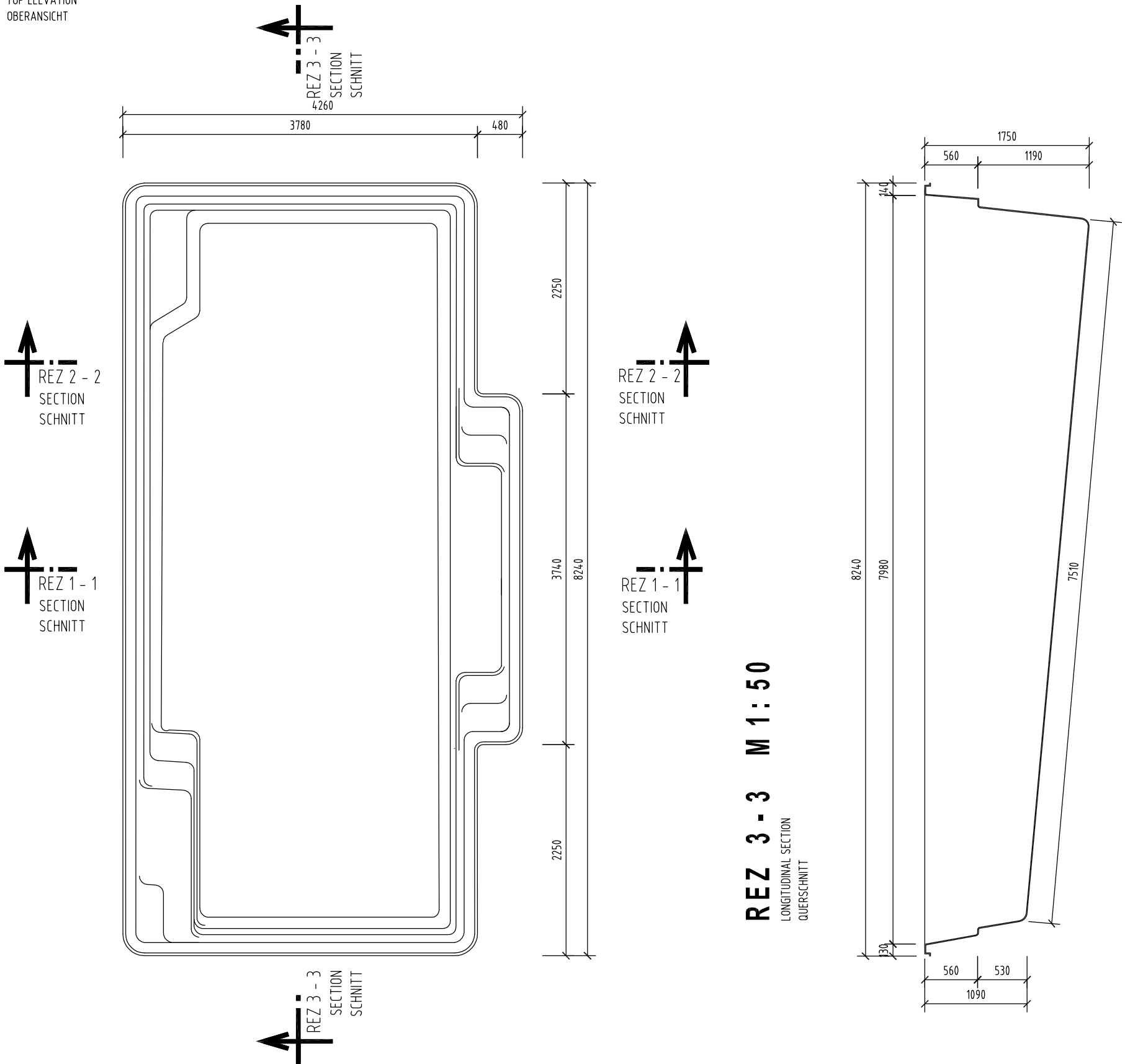

## REZ 1 - 1 M 1:50

CROSS SECTION  
QUERSCHNITT

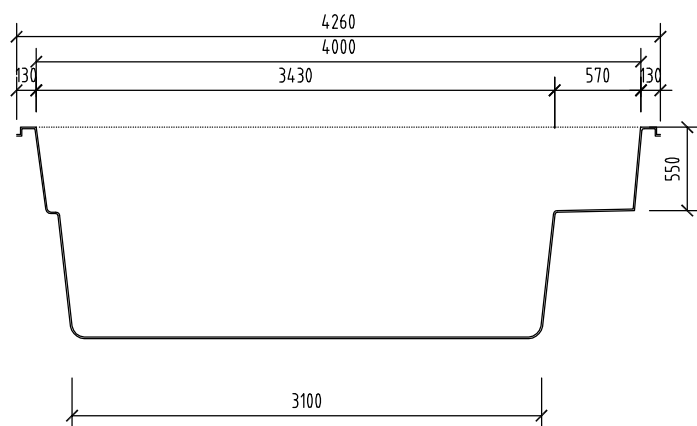

## REZ 2 - 2 M 1:50

CROSS SECTION  
QUERSCHNITT

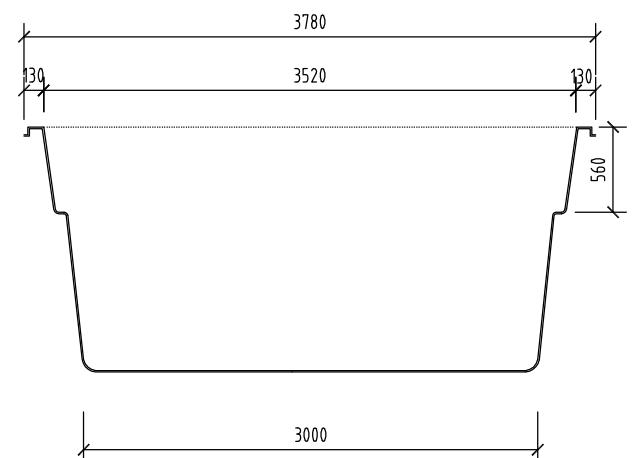

POZNÁMKA / NOTE / ANMERKUNG :

HRÚBKA STENY BAZÉNA JE CCA. 10 MM  
TOLERANCIA PRESNOSTI 7 - 10 MM

THICKNESS OF THE SIDEWALL OF SWIMMING POOL IS APX. 10 MM.  
MEASURED WITH TOLERANCE RATE 7 - 10 MM

DIE SCHWIMMBADWAND DÜCKE IS CA. 10 MM.  
DUCKENTOLERANZ IST 7 - 10 MM.

NÁZOV VÝKRESU:  
DRAWING NAME:  
ZEICHNUNG NAME:

**VOGUE 82**  
**GEOMETRIA BAZÉNA**  
**GEOMETRY OF SWIMMING POOL**  
**SCHWIMMBAD GEOMETRIE**

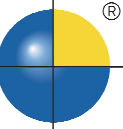
<b>Compass</b> 	
Ceramic Pools Europe	
<a href="http://www.compasspools.eu">www.compasspools.eu</a>	
KRESLIL: DRAWER / ZEICHNER:	ING. PETER KALETÁ
DÁTUM: DATE / DATUM:	05/2012
MIERKA: SCALE/MASSTABE:	1:50
FORMÁT DRAWING FORMAT / ZEICHNUNG FORMAT:	A3
VERZIA: VERSION: VERSION:	2
ČÍSLO DRAWING NUMBER: ZEICHNUNG NUMBER:	<b>3</b>